

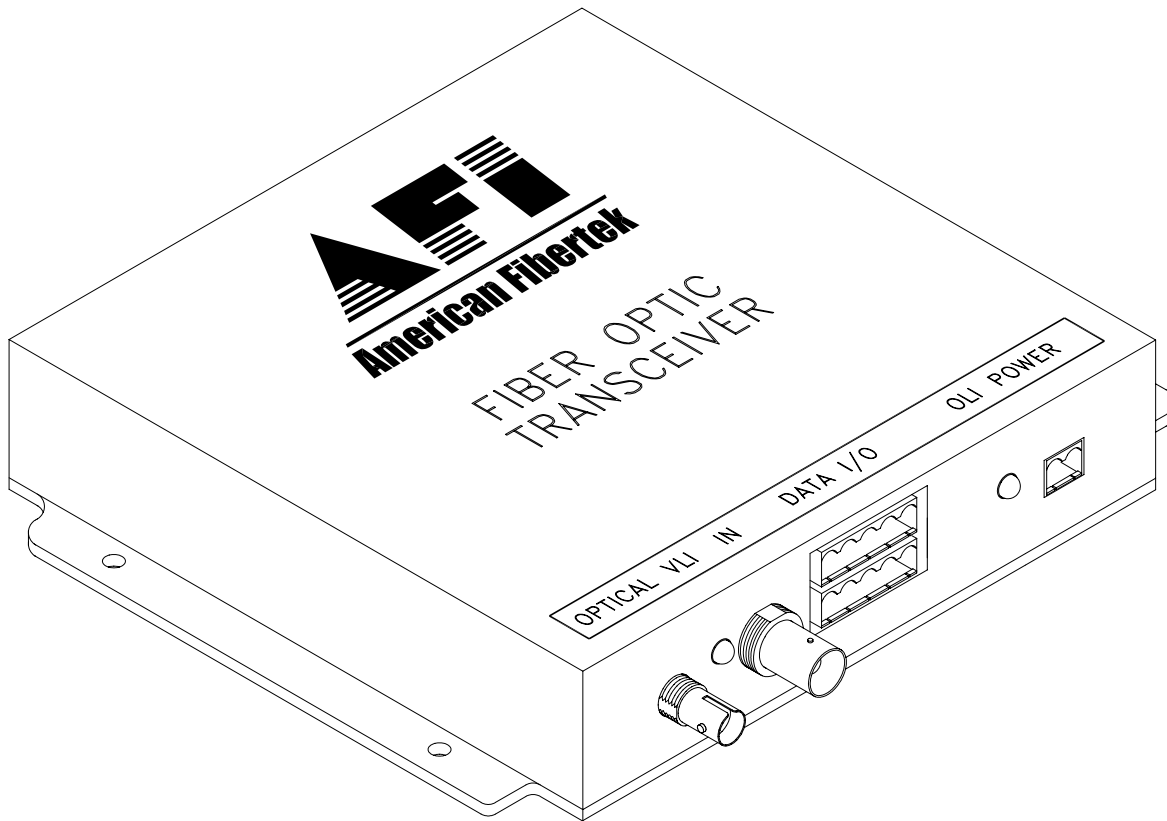

120 Belmont Drive
Somerset, NJ 08873-1204

American Fibertek

Phone: 732.302.0660 Fax: 732.302.0667



Instruction Manual

MT-1890

Video Transmitter With
Bi-directional 4-Wire Audio
And Bi-directional Contact Closure

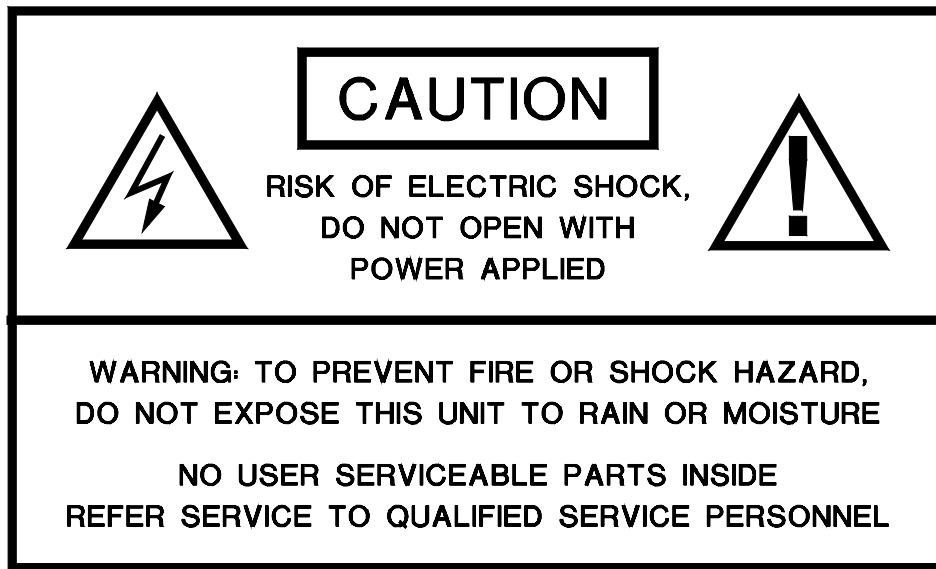

INSTALLATION AND OPERATION INSTRUCTIONS

INTRODUCTION

Thank you for purchasing your American Fibertek MT-1890 multimode video transmitter with bi-directional audio and contact closure. Please take a few minutes to read these installation instructions in order to obtain the maximum performance from this product.

FUNCTIONAL DESCRIPTION

The MT-1890 operates as half of a transmitter/receiver pair for the transmission of baseband NTSC, PAL, RS170, or RS343 video signals with one channel of bi-directional 4 wire audio and one channel of bi-directional contact closure. It is designed to operate with the MR-1890 or RR-1890 video receiver over a single multimode fiber optic cable.

The MT-1890 converts a video input, an audio input, and a contact input into an optical output using a 1300 nm wavelength source. The MT-1890 also converts an optical input signal returning on the same fiber into a single audio output and a contact output using an 850 nm wavelength detector. The 1890 Series product is designed to operate over an optical loss budget range of 0 to 12 dB. The MT-1890 operates on 50 um or 62.5 um multimode fiber. Refer to the data sheets for detailed performance specifications.

This unit is contained in a compact and rugged aluminum housing with internal dc voltage regulation. The detachable terminal blocks and LED indicators provide for easy installation and monitoring of video, optical, and ac power.

The MT-1890 is designed for mounting as a modular stand alone unit. For a rack mounted version please see the RT-1890.

INSTALLATION

THIS INSTALLATION SHOULD BE MADE BY A QUALIFIED SERVICE PERSON AND SHOULD CONFORM TO THE NATIONAL ELECTRICAL CODE, ANSI/NFPA 70 AND LOCAL CODES.

Mount the unit to a secure surface using #8 (3mm) hardware in four places. See the drawing on the next page for mounting dimensions. Be sure to allow sufficient room for the required minimum bend radius of the fiber cable used.

POWER SOURCE

THIS PRODUCT SHALL BE POWERED BY A LISTED CLASS 2 POWER SUPPLY ONLY.

This unit requires an isolated 24VAC power source for proper operation. In the USA and in Canada an American Fibertek PS-24 is supplied with this unit. ANSI/NFPA 70 Class 2 wiring is recommended.

POWER CONNECTION

Power is supplied to the unit via a two pin terminal connector on the side of the unit. See label on unit for proper location of input power.

FIBER CONNECTION

The fiber optic connection is made via a ST connector located on the side of the unit.

VIDEO INPUT CONNECTION

The video input connection is made via a BNC connector on the side of the unit. The video input should be connected to an appropriate 75Ω baseband video source such as a camera or a video recorder output. For optimum performance the video cable should be the shortest length of coax practical.

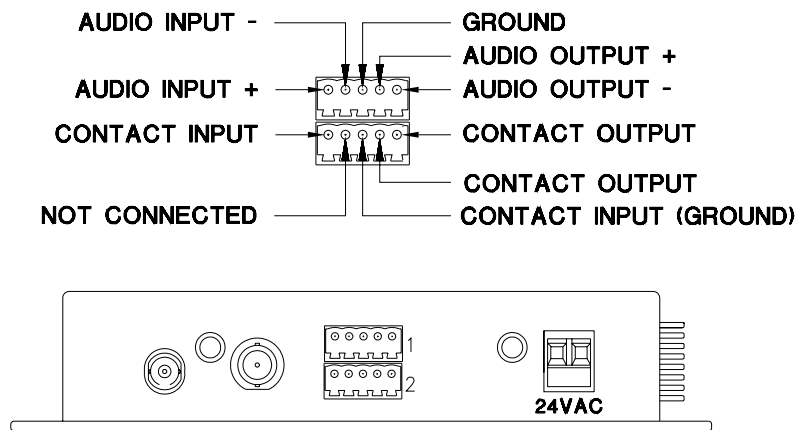
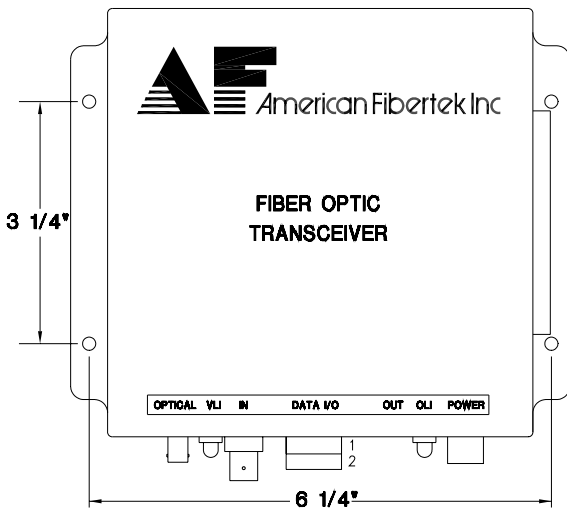

CONTACT CLOSURE INPUT / OUTPUT CONNECTIONS

Contact closure input and output connections are made via terminal blocks on the side of the unit. Contact input becomes a closure when a short is created between CONTACT INPUT and CONTACT INPUT GROUND. This forces the CONTACT INPUT signal to ground which will produce a short between the CONTACT OUTPUT terminals on the MR-1890 or RR-1890 unit.

AUDIO INPUT / OUTPUT CONNECTIONS

Audio input and output connections are made via terminal blocks on the side of the unit. In a balanced audio configuration, the input connection is made across the plus and the minus terminals. In an unbalanced configuration, the plus terminal is used for the input audio connection with the minus and ground terminals used for the ground connection. In a balanced audio configuration, the output connection is made across both the plus and the minus terminals. To connect unbalanced, the plus output terminal is used for the audio connection, along with the ground terminal. Please note that Audio In on the MT-1890 becomes Audio Out on the MR-1890 or RR-1890 after going across the fiber. The reverse flow follows the same orientation. For optimum performance the audio cables should be the shortest length of wire practical.

AUDIO INPUT/ OUTPUT LEVELS

The ideal audio input level is 0dBm₆₀₀. (This is 1mW across the 600 Ohm input impedance.) On a voltage basis, this is equal to 0dBV or 2.19 Vp-p. Higher input levels will cause increased distortion. Up to +3dBm, the distortion will increase a small amount. Above this level the distortion will increase rapidly. Lower input signal levels will reduce the signal to noise ratio. In either balanced or unbalanced configuration, the input impedance is 600 Ohms.

The audio output signal appears on both the plus and minus terminals of this unit. Half of the signal appears on each output terminal. The two outputs are 180° out of phase. The balanced output impedance is 600 Ohms while the unbalanced output impedance is 300 Ohms. The output signal level will be half of the input level (-6dB) in an unbalanced configuration.

MT-1890 STATUS INDICATORS

The MT-1890 provides the following LED status indicators to aid in installation and troubleshooting:

VLI

A bi-color LED indicator is provided for the video input to the MT-1890. Internal DC power and video status associated with this LED is summarized below.

Video Presence LED	DC Power Status	Video Status
Green	On	Proper Input Video Present
Red	On	Input Video Not Detected
Off	Off	Check Power Supply Input

OLI

A bi-color LED indicator monitors the optical input power of the audio/contact closure signal that is being received at the MT-1890 from the MR-1890 or the RR-1890. Internal DC power and optical input status associated with this LED are summarized below.

Optical Level Indicator	DC Power Status	Optical Status
Green	On	Proper Optical Input Power Present
Red	On	Optical Input Not Detected
Off	Off	Check Power Supply

LIFETIME WARRANTY INFORMATION

American Fibertek, Inc warrants that at the time of delivery the products delivered will be free of defects in materials and workmanship. Defective products will be repaired or replaced at the exclusive option of American Fibertek. A Return Material Authorization (RMA) number is required to send the products back in case of return. All returns must be shipped prepaid. This warranty is void if the products have been tampered with. This warranty shall be construed in accordance with New Jersey law and the courts of New Jersey shall have exclusive jurisdiction over this contract. **EXCEPT FOR THE FOREGOING WARRANTY, THERE IS NO WARRANTY OF MERCHANTABILITY OR FITNESS FOR A PARTICULAR PURPOSE OR OTHERWISE, EXPRESSED OR IMPLIED, WHICH EXTENDS BEYOND THE WARRANTY SET FORTH IN THIS AGREEMENT.** In any event, American Fibertek will not be responsible or liable for contingent, consequential, or incidental damages. No agreement or understanding, expressed or implied, except as set forth in this warranty, will be binding upon American Fibertek unless in writing, signed by a duly authorized officer of American Fibertek.

SERVICE INFORMATION

There are no user serviceable parts inside the unit.

In the event that service is required to this unit, please direct all inquiries to:

American Fibertek, Inc.
120 Belmont Drive
Somerset, NJ 08873

Phone: (877) 234-7200
Phone: (732) 302-0660
FAX (732) 302-0667

E-mail: techinfo@americanfibertek.com